



**FIXD IP DOME CAMERA
FIXD MEGAPIXEL IP DOME CAMERA**

VN-V225U

VN-X235U

**INSTRUCTIONS
(Installation)**

- This is a supplementary instruction manual to [READ ME FIRST]. Please read through this manual together with the bundled [READ ME FIRST] (sheet).
- For image and network settings, please refer to [INSTRUCTIONS (Setting)].

Features

High picture quality

The camera employs a progressive CCD with a resolution of about 330,000 pixels (1/4"), which enables video surveillance using high-quality images. (VN-V225U)

The camera employs a progressive CCD with a resolution of about 1.25 megapixels (1/3"), which enables video surveillance using high-definition and high-quality images. (VN-X235U)

Wider shooting range

The adjustable range for the shooting direction is very wide, and the rotation control mechanism enables the camera to be mounted to the wall surface.

Unblocked Design

The dome-shaped design enables ease of use without being blocked by the camera.

Embedding to the ceiling without brackets

There is no need to prepare brackets for embedding the camera to the ceiling.

High zoom ratio varifocal lens

The camera comes with a built-in varifocal lens with an optical zoom ratio of 3.6x (VN-V225U) and 3x (VN-X235U) for more detailed surveillance.

Support for PoE (Power over Ethernet)

This camera supports PoE (IEEE802.3af) and enables power supply through a LAN cable.

Supports night surveillance

Surveillance under low illumination, such as during night time, is possible by turning the infrared cut filter Off to switch to the high-sensitivity mode (black-and-white mode).

Electronic Sense Up function

During surveillance at a dimly lit location, shooting can be performed by lengthening the exposure time to increase the sensitivity of the camera.

High frame rate

Data transmission is possible in VGA size (640 x 480) at a rate of 30 fps. (VN-V225U)

Data transmission is possible in Quad-VGA size (1280 x 960) at a rate of 15 fps. (VN-X235U)

Support for dual stream

JPEG and MPEG images can be distributed simultaneously.

Support for multicast

This product supports multicast, which enables transmission of image data to multiple computers on the network without lowering the frame rate.

Built-in web server

You can configure the picture quality and communication settings using the Internet Explorer.

HTTP-based API

This product comes with HTTP-based API. This feature enables you to perform setting and control via the network.

Built-in JPEG and MPEG4 Viewer

Monitoring on a PC is possible by downloading the built-in viewer to the PC.

Motion detection feature

This feature enables output of an alarm upon detection of motion in the video image within preset area.

FTP transmission of pre-/post-recorded image files is possible using the alarm input.

Digital PTZ functions (VN-X235U)

This camera comes with a digital PTZ (Pan/Tilt/Zoom) function, which enables you to clip and enlarge a specific area to monitor from the image that is being captured. This allows surveillance to be performed on a wide field of view using a small bandwidth.

Privacy mask function

You can configure the privacy mask setting to exclude a specific area from the targeted shooting area.

The shape and location of the mask can be set as required.

Support for audio input/output

Audio sound can be sent to a PC by connecting an external microphone. Also, audio sound input to the PC can be output through an audio signal input/output cable via the network.

Analog signal output (for installation)

This camera is equipped with an analog video monitor signal output terminal, which is used for adjusting the camera angle during installation.

Saving JPEG images to the FTP server at regular intervals

JPEG images may be uploaded to the FTP server at regular intervals.

Alarm input/output

This camera comes with a motion detection feature and dual alarm input.

During motion detection or alarm input, actions such as mail delivery, message transmission via TCP/UDP, alarm output, or a combination of any two actions can be triggered.

Installing an FTP server enables uploading of images before and after the alarm input time (pre-/post-recording) to the server.

Fine focus adjust

This feature eases fine-tuning of the focus, and enables focus to be accurately adjusted speedily.

How to read this INSTRUCTIONS (Installation)

■ Symbols used in this manual

- Note : States precautions to be taken during operation.
- Memo : States restrictions on the functions or use of this equipment. For reference purposes.
-  : Indicates the page numbers or items to refer to.

■ Contents of this manual

- JVC holds the copyright to this manual. Any part or all of this manual may not be reproduced without prior consent from the company.
- Windows is a registered trademark of Microsoft Corporation in the U.S.
- Product names of other companies described in this manual are trademarks or registered trademarks of the respective companies. Symbols such as TM, ® and © are omitted in this manual.
- Design, specifications and other contents described in this manual are subject to change for improvements without prior notice.

Contents

Getting Started

Features	2
Contents	3
Precautions	4
Name and Function of Parts.....	6

Connection/Installation

Mounting the Camera.....	10
Embedding the Camera into the Ceiling	10
Mounting with the cables pulled out from the side	12
Connecting the Alarm Input/Output Cable	13

Others

Troubleshooting	14
Specifications	15

Precautions

Storage and Operating Environment

- This product is an indoor camera. It cannot be used outdoors.
- Do not store in the following environments. It might result in malfunctions or failure.
 - Hot or cold locations beyond the allowable operating temperature range of -10 °C to 50 °C
 - Locations beyond the allowable operating humidity range of 35 % RH to 90 % RH (condensation is not allowed)
 - Near equipment that emits strong magnetic fields, such as transformers or motors
 - Near equipment that emits radio waves, such as transceivers and mobile phones
 - Locations with excessive dust and sand
 - Locations that are subject to strong vibrations
 - Locations prone to moisture such as window side
 - Locations that are subject to steam or oil, such as kitchens
 - Locations that are subject to emission of radiation, X-rays or corrosive gases
- Use of this product and cables connected to this product at locations where strong electric waves and magnetic waves are generated (e.g., near radio, TV, transformer, monitor, etc.) may cause noise interferences in the images or changes in the color.
- Do not install this camera at a location that is directly subject to cold air, or near the discharge outlet of an air-conditioner. Drastic changes in the temperature may fog up the dome cover.
- Do not install this camera at a location that traps heat
This product also discharges heat from the surface of the main unit. Do not install it at locations that may trap heat, such as the corner of a wall.

Handling Precautions

- Do not block the vents
Inadequate heat ventilation may result in malfunction of this product. Be sure not to block the vents around the product.

Copyright Protection

- With the exception of the user being the copyright holder or when permission such as for duplication has been granted by the copyright holder, permission is required in principle for the duplication, modification, or transmission of copyrighted video and audio data.
- Unauthorized duplication, modification, or transmission of copyrighted material may constitute a copyright infringement, and the user may be liable to compensate for any damages. When using copyrighted video/ audio data, be sure to check the license agreement of the copyrighted material thoroughly.
- When rights or rights holders are involved with regard to the targeted duplicating subject, permission may be required for shooting or using (processing) it. Be sure to check the licensing conditions thoroughly.

Disclaimer

- The motion detection feature is not a feature to prevent theft or fire. Our company shall not be liable for any loss or damage resulting from the use of this feature.
- We shall not be responsible for any loss or damage caused in the event of privacy invasion as a result of the camera footages of this product.

Maintenance

- Turn off the power before performing maintenance.
- Wipe using a soft cloth.
Wiping with thinner or benzene may melt or tarnish its surface. For tough stains, wipe using a cloth that is dipped into a neutral detergent diluted with water, followed by wiping with a dry cloth.

Saving Energy

- If the camera is not to be used for a long time, turn off the power of the system for safety and energy conservation reasons.

Others

- This camera comes with a built-in AGC circuit. Setting AGC to “Mid”, “High” or “Super” increases the sensitivity of a dark image, and the screen may appear grainy. This is not a malfunction.
- When this camera is used with the white balance set to “ATW” (Auto Tracking White Balance), the color tone of some objects may differ slightly from the actual color due to the principle of the automatic tracking white balance circuit. This is not a malfunction.
- If a high brightness subject (such as a lamp) is shot, vertical lines may appear in the image displayed on the screen (smear), or bleeding may appear around the bright subject (blooming). These phenomena are characteristics of the CCD, and are not caused by malfunction of the camera.
- For regions with a commercial power supply frequency of 50 Hz, switch to the Flickerless mode during use under fluorescent lights (excluding inverter lighting equipment) to prevent flickers.
- When switching between color and black-and-white images in the B&W mode, the brighter area on the screen is emphasized, which may reduce the visibility. However, this is not a malfunction.
- When the electronic sensitivity enhancement feature is enabled, the screen may appear grainy and more white spots may appear as the sensitivity is increased. However, this is not a malfunction.
- If the power supply voltage is momentarily cut off or reduced due to lightning or turning on of the air conditioner's power, the image may be disrupted or noise interference may occur.
- The rotation angle of this camera is increased to enable installation at a wider variety of locations. When the zoom of the lens is at the wide end, and tilted at an angle close to $\pm 80^\circ$, a part of the camera may come into view on the screen depending on the rotation angle. When this occurs, adjust the field angle accordingly.
- When using multicast, make use of an IGMPv2-compliant network switch.
- Power can be supplied to this camera either by using PoE or connecting to an AC 24 V power supply. Make sure that power is supplied using only one of the above methods at any one time. Connecting simultaneously using the power cable and to PoE via a LAN cable may cause the camera to break down or malfunction.
- Some hubs/switches of products that are equipped with intelligent features may include a broadcast/multicast suppression function. Viewing of multicast images on this product may fail if this function is enabled.
- During viewing using the integrated viewer, the video and audio sound may appear out-of-sync. This is not a malfunction.
- It is recommended to use shielded LAN cables, shielded alarm cables and shielded audio cables for connection with this product. The safety and reliability of this product has been checked by using shielded cables.

Name and Function of Parts

Camera

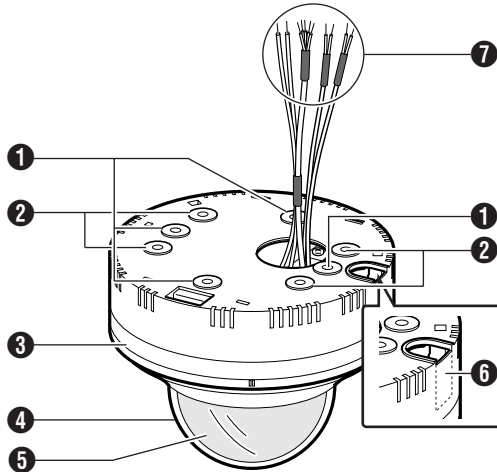

① Mounting holes (oval) × 4

Use these holes when mounting the camera directly to the ceiling or a wall.

② Mounting holes (round) × 4

Use these holes when mounting the camera directly to the ceiling or a wall. They are also used for mounting the camera to an electrical box.

Note:

- To mount the camera using an electrical box, please consult the dealer shop from which the camera is purchased or any nearby JVC Service Centers.

③ Outer casing

Use these holes when mounting the camera directly to the ceiling or a wall.

④ Dome cover

⑤ Inner dome

⑥ Cable outlet

Use this outlet to pull out the cable from the side of the camera without making a hole in the ceiling. Break the section marked by a dotted line, and pull out the cable.

(☞ page 12)

⑦ Alarm cable/Audio cable/Power cable

(☞ [READ ME FIRST])

Type	Color		Signal name
Alarm cable	Black (Shielded cable)	Red	Alarm input 1
		Brown	Alarm input 2
		Orange	Alarm output 1
		Yellow	Alarm output 2
		Black	GND
Audio cable	Pink (Shielded cable)	White	Microphone input
		Yellow	GND
	Black (Shielded cable)	White	Line output
		Yellow	GND
Power cable	Red (Unshielded cable)	AC 24 V Power Supply	
	Black (Unshielded cable)		

Note:

- Do not use PoE and an AC24 V power supply at the same time. Doing so may cause the camera to break down or malfunction.

Camera Body/Interior

* The following is an illustration when the dome cover, inner dome, and outer casing are removed.
Removal procedures (☞ page 11 “Remove the outer casing”)

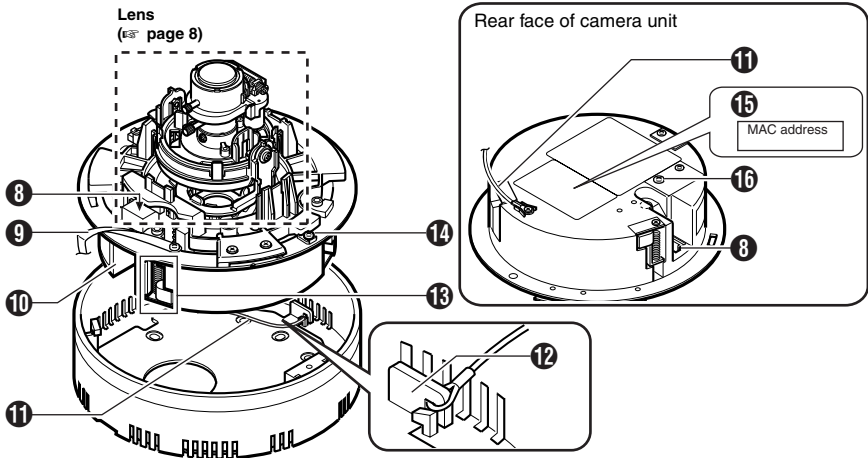

8 [10BASE-T/100BASE-TX(PoE)] LAN cable connector (RJ-45)

9 Fall prevention sheet

This sheet connects the camera unit with the dome cover.

10 Camera Unit

11 Fall prevention wire (supplied) and wire mounting screw

Connects the camera unit **10** with the outer casing **3** using the fall prevention wire fastening hook **12**.

12 Fall prevention wire fastening hook

13 Ceiling mounting brackets (x3)

These brackets are used when embedding the camera to the ceiling. (☞ page 10)

14 Camera unit fastening screw

Fastens the camera unit **10** and the outer casing **3**.
How to remove (☞ page 11)

15 [MAC address] indication

The MAC address is a unique physical address of the product. This address cannot be altered.

16 Fall prevention wire mounting screw

Use the screw for attaching the fall prevention wire from the ceiling.
(Fall prevention wire is not provided.)

Name and Function of Parts (continued)

Lens

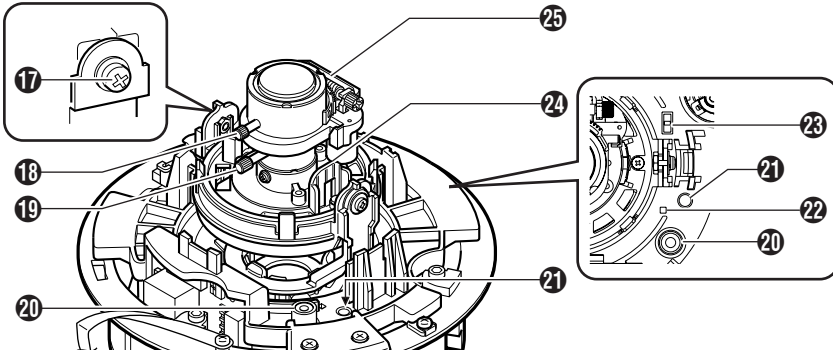

17 Tilt fastening screw

Note:

- After adjusting the field angle, tighten the tilt fastening screw to secure the camera so that its field angle does not go out of alignment. (☞ [READ ME FIRST])

18 Focus adjustment ring

Move the ring to the left and right to adjust the focus.

(☞ [READ ME FIRST])

19 Zoom adjustment ring

Move the ring to the left and right to adjust the field angle.

(☞ [READ ME FIRST])

20 [MONITOR] terminal (pin jack)

(☞ [READ ME FIRST])

21 [RESET] button

This button has two functions as described below, depending how it is being pressed.

- Reset function (press for less than 2 seconds and release)

Reboots the camera. Reboot takes about 1 minute. During this interval, the [RESET] button is disabled.

- Focus adjust function (press for at least 2 seconds and release in less than 5 seconds)

The camera enters the focus adjust mode and the status indicator 22 blinks in green and orange alternately.

This function can also be used on the viewer. Refer to [INSTRUCTIONS (Setting)].

Note:

- During the focus adjust mode, the screen may flicker when the electronic shutter is operating. This is not a malfunction.
- Pressing this button for 5 seconds or longer switches the camera to the Service Check mode. The status indicator lights up in orange color in this mode. Do not press the button for 5 seconds or longer.
- To make use of the focus adjust function of the Reset button, restart the camera after setting the [MONITOR OUT] output selection switch 23 to "N" or "P".

23 Status indicator

Indicates the current status of the camera.

Starting up : Lights up in orange
After startup is complete : Lights up in green
Error : Blinks in orange

Memo:

- When the camera is in the focus adjust mode, the status indicator blinks in green and orange alternately.
 - The indicator light after startup can be set to off or blink in green using the [LED State] of the integrated viewer. To alter the settings of the LED indicator, refer to [INSTRUCTIONS (Setting)].
-

23 [MONITOR OUT] selection switch

Use this switch to select whether to send output from the [MONITOR] terminal ⑳, and also the corresponding signal format.

[N] : Select this when connecting to an NTSC-compatible monitor.
[OFF] : Disables output. Select this setting when sending images to the network.
[P] : Select this when connecting to a PAL-compatible monitor.
[Default setting : "OFF"]

Note:

- Images are not sent to the network when this is set to "N" or "P".
 - When the switch setting is altered, press the [RESET] button for less than 2 seconds to reboot the camera.
-

24 Rotation control

Adjusts the inclination of the image by rotating the lens unit with the center of the lens as the axis.

( [READ ME FIRST])

Note:

- Do not hold the lens section when adjusting the camera direction. The lens section may be damaged if you apply force to it.
-

25 [FOCUS ADJ] fine focus adjust

This is used to focus the lens.

( [READ ME FIRST])

Mounting the Camera

Selecting a Mounting Method

The procedures vary according to the mounting method. Mount the camera accordingly by referring to the respective section.

Note:

- Be sure to put on protective glasses to protect your eyes from falling objects when mounting the camera to the ceiling.
- To mount the camera using an electrical box, please consult the dealer shop from which the camera is purchased or any nearby JVC Service Centers.

Mounting Methods

- **Embedding into the ceiling** (☞ page 10)
- **Mounting directly to the ceiling or the wall** (☞ [READ ME FIRST])
- **Mounting with the cables pulled out from the side** (☞ page 12)

Warning

- Special attention is required when mounting the camera to a wall or ceiling. Make sure that the mounting work is performed by a specialist. Improper mounting may cause the camera to fall off and result in injuries.
- We are not liable for any damage, injury or other problems caused by a camera that has fallen off due to failure to follow the installation instructions and improper mounting. Pay careful attention during mounting.
- To prevent the camera from falling off, mount it to a firm place (ceiling slab or channel) using a fall prevention wire.
- Take note of the length, strength, pull and material (insulation) of the fall prevention wire.
- Insufficient tightening of the mounting screws and nuts may cause the camera to fall off. Make sure that there are properly and firmly tightened.
- Do not mount the camera near lighting equipment that may be heated up to a high temperature, such as a spotlight. This may result in malfunction of the equipment or cause fire.

Embedding the Camera into the Ceiling

- ※ The camera can be mounted to ceilings with a thickness between 9.5 mm and 22 mm.

■ Preparation

1 Make a hole in the ceiling (ø120 mm)

2 Pull out the cables from the hole in the ceiling

Pull out the fall prevention wire, LAN cable, power cable, alarm cable, and audio cable that are attached to the ceiling slab from the hole. (Fall prevention wire is not provided)

Note:

- Take note of the length, strength, pull and material (insulation) of the fall prevention wire.
- The inner diameter of the ring section of the fall prevention wire to be mounted to the camera should be between ø3.1 mm and ø5.5 mm, and the outer diameter not larger than ø9 mm.

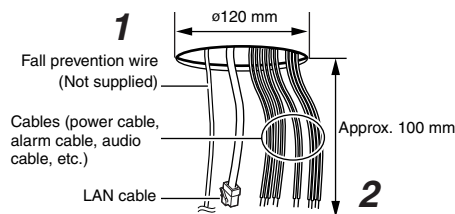

3 Remove the dome cover

Turn the dome cover in the anti-clockwise direction to remove it. To prevent damage to the dome cover, a protection sheet is affixed.

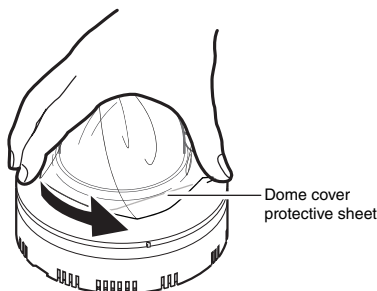

4 Remove the inner dome

The inner dome is fastened using 2 catches.
Remove the inner dome by unfastening it from the catches.

5 Remove the outer casing

(This mounting method does not make use of an outer casing.)

- 1 Remove the fastening screw from the camera unit using a screwdriver
- 2 Turn the camera unit in the anti-clockwise direction to remove the outer casing

6 Remove the attached fall prevention wire

Remove the fall prevention wire that is attached to the camera unit.

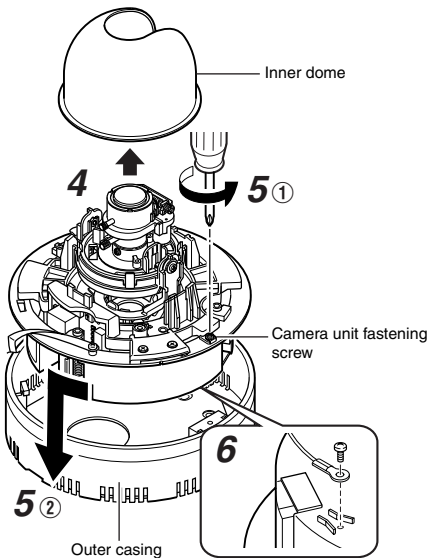

■ Connection

Memo:

- For details, please also refer to the [READ ME FIRST] (sheet) provided.

Note:

- For your safety, turn on the power only after all connections are completed.

1 Mount the fall prevention wire that connects the camera and the ceiling

2 Connect the alarm cables and audio cables

3 Connect the LAN cable

4 Connect the power cable

Note:

- Connection of a power cable is not necessary when PoE is used.

Memo:

- For cables that are not used, be sure to wrap the ends individually with insulating tape.

5 Insert the camera unit into the hole in the ceiling

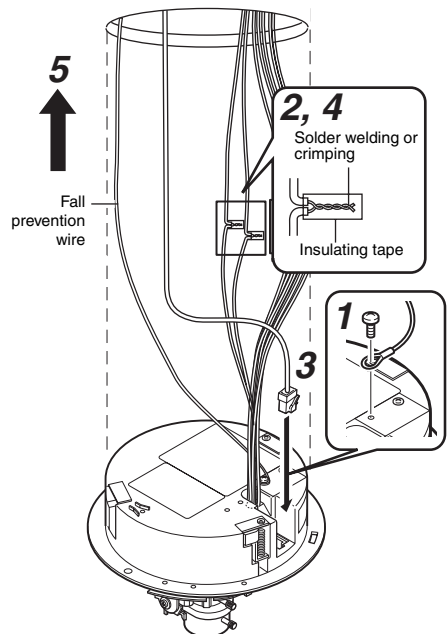

Mounting the Camera (continued)

■ Mounting

1 Align the shooting direction with the shooting direction mark (↑), followed by mounting the camera

2 Fasten the camera (x3 locations)

- 1 Turn the tip of the ceiling mounting bracket such as by using a screwdriver
- 2 The camera is fastened after the ceiling mounting brackets are hooked to the ceiling

Memo:

- To remove the camera, perform the above procedure in the reverse sequence.

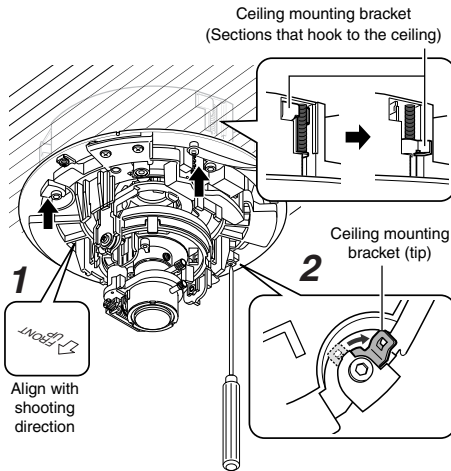

■ Image Adjustment

After mounting is complete, adjust the video image while referring to the actual display on the monitor.

(☞ [READ ME FIRST])

■ Mounting the Dome Cover

After video image adjustment is complete, mount the inner dome and dome cover accordingly. Installation is complete after the dome cover is mounted and the protective sheet removed.

(☞ [READ ME FIRST])

Mounting with the cables pulled out from the side

When mounting the camera to the ceiling or wall, you can pull out the cables from the side without having to make a hole in the ceiling.

Memo:

- The basic mounting procedures are identical to those described for “Direct mounting to the ceiling/horizontal mounting to the wall”.
- For details on mounting, please refer to the [READ ME FIRST] (sheet) provided.

1 Break the portion illustrated by the dotted lines in the diagram such as by using a pair of radio pliers

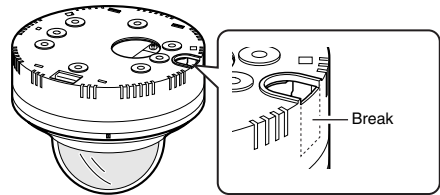

2 Mount the outer casing to the ceiling or wall

3 Pull out the cables from the cable outlet

4 Connect the cables

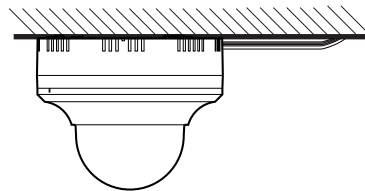

Connecting the Alarm Input/Output Cable

Alarm Input

Connect the cable to sensors such as infrared sensors, door sensors, metal sensors and manual switches.

Input Requirements

- Non-voltage relay NPN open collector input
- Polarity of input detection can be selected using a software
- Make/break (500 ms and above)
- Circuit current of 1 mA during low-level input
- Applied voltage of 3.3 V during high-level input

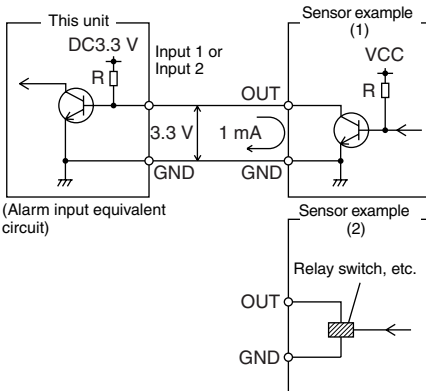

Alarm output

Connect to alarm devices such as alarm, indicator, light or buzzer.

Output Requirements

- NPN open collector output equivalent (Refer to the INSTRUCTIONS (Setting) on procedures to set the output logic.)
- Allowable applied voltage: DC 12 V and below
- Allowable inflow current: 50 mA
- Momentary (100 ms to 5000 ms) output (Refer to [INSTRUCTIONS (Setting)] for procedures to set the time.)

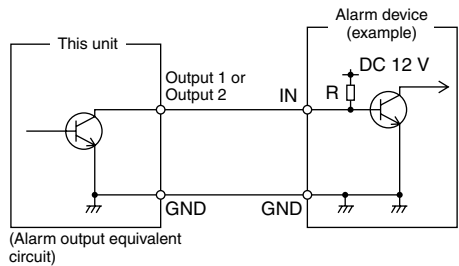

Note:

- Connect the GND cable of the camera to the GND terminal of the alarm device.

Troubleshooting

Symptom	Causes and Countermeasures
Images are not output to the monitor	<ul style="list-style-type: none"> ● Set the [MONITOR OUT] selection switch to “N” or “P”, and press the Reset button. ● When using the [MONITOR] output, set the privacy mask to “Off”. (☞ [INSTRUCTIONS (Setting)])
Band noise is found at the lower part of the monitor image	<ul style="list-style-type: none"> ● When using the [MONITOR] output, set the privacy mask to “Off”.
Images via the network are disrupted	<ul style="list-style-type: none"> ● Set the [MONITOR OUT] selection switch to “OFF”, and press the [RESET] button for less than 2 seconds.
No audio sound is heard from the external microphone	<ul style="list-style-type: none"> ● Check the connection between the external microphone and the camera.

Specifications

CAMERA HEAD

Image pickup device

VN-V225U : 1/4" square pixel
progressive-scan CCD
(complementary filter)

VN-X235U : 1/3" square pixel
progressive-scan CCD
(complementary filter)

Effective pixels

VN-V225U : Approx. 330,000 pixels
659 (H) × 494 (V)

VN-X235U : Approx. 1,250,000 pixels
1296 (H) × 966 (V)

Monitor output

Monitor output × 1 (75 Ω, 1 Vp-p)

Minimum brightness of object (VN-V225U)

Color : 0.4 lx (typ., 50 %, F1.2, AGC
Super, 1/30 s)

Black-and-white : 0.03 lx (typ., 50 %, F1.2,
AGC Super, 1/30 s)

Minimum brightness of object (VN-X235U)

Color : 0.8 lx (typ., 50 %, F1.2, AGC
Super, 1/30 s)

Black-and-white : 0.08 lx (typ., 50 %, F1.2,
AGC Super, 1/30 s)

Audio input

Connection of plug-in power microphone
supported

Reference voltage

: DC 2.7 V (typ.),
impedance : 2.2 kΩ (typ.)

Audio output

Line output (200 Ω, max. 2 Vp-p)

Network output

Image compression format

: JPEG, MPEG4

Frame size : 1280 × 960 (VN-X235U only)

640 × 480

320 × 240

Horizontal resolution

VN-V225U : 400 TV lines (typ.)

VN-X235U : 700 TV lines (typ.)

Network interface

: RJ-45

100BASE-TX/10BASE-T/
FULL/HALF/Auto negotiation
supported

Lens

VN-V225U

Focal length : f=2.8 mm to 10.5 mm

Maximum aperture ratio

: F1.2 (f=2.8 mm) to F2.7
(f=10.5 mm)

Aperture range : F1.2 to F360

Field angle adjustment

: 3.75x

IR filter : Switchable

VN-X235U

Focal length : f=3 mm to 9 mm

Maximum aperture ratio

: F1.2 (f=3 mm) to
F2.1 (f=9 mm)

Aperture range : F1.2 to F360

Field angle adjustment

: 3x

IR filter : Switchable

LAN specifications

Compliant with IEEE802.3, IEEE802.3u and
IEEE802.3af

Communication protocols

: TCP/IP, UDP/IP, HTTP, FTP,
ICMP, ARP, RTP, DHCP,
SNTP, SMTP, IPv4, IPv6,
DSCP, and IGMP

Specifications (continued)

Overall

Alarm input ×2	: No-voltage a contact input, NPN open collector input, low-level input, latch/momentary (500 ms and above) input (circuit current during low-level input: 1 mA; applied voltage during high-level input: DC 3.3 V)
Alarm output ×2	: NPN open collector output (allowable applied voltage: 12 V; allowable inflow current: 50 mA)
Internal memory	: 8 MB
Supply voltage	: AC 24 V or PoE (DC -48 V)
Current consumption	: AC 24 V 0.35 A PoE 7 W
Surrounding temperature	: -10 °C to 50 °C (operation) 0 °C to 40 °C (recommended)
Ambient humidity	: 35 % RH to 90 % RH (without condensation)
Mass	: Approx. 750 g (1.65 lbs)

Accessories

Safety Precautions	1
Read Me First	1
CD-ROM	1
Warranty Card (For USA)	1
Service Information Card (For USA)	1
Template	1

Dimension [Unit: mm (inches)]

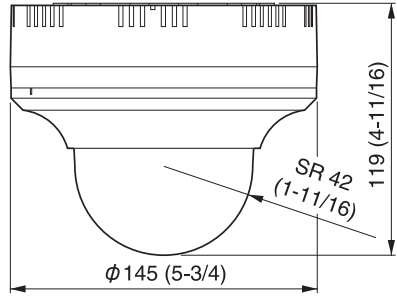
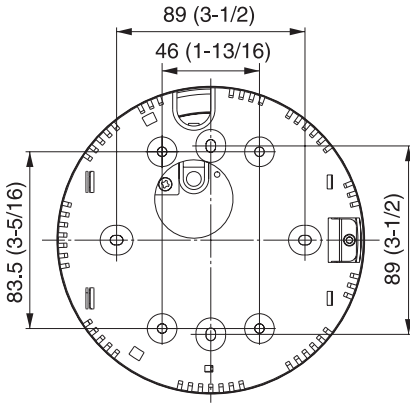

* Specifications and appearance of this unit are subject to change for further improvements without prior notice.

**VN-V225U/VN-X235U
FIXD IP DOME CAMERA /
FIXD MEGAPIXEL IP DOME CAMERA**

JVC